

ebm-papst EC communication

Hardware and software
for EC bus systems

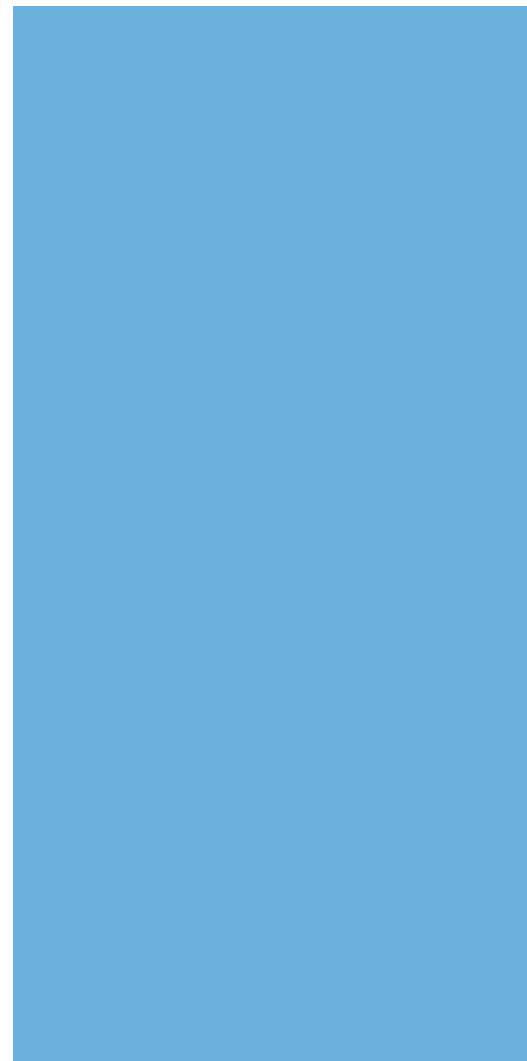

The best connections for a flexible control system



The engineer's choice

ebmpapst

Communication on all channels

Fan networks made up of ebm-papst EC fans render their service in refrigeration and air-conditioning technology, in building ventilation, clean rooms and many other application areas. For communication with the bus systems, the ebm-papst product range provides various interfaces and software solutions that give you optimum support for setting up and monitoring networks.

Open and closed-loop control, programming, measuring

In addition to their outstanding energy efficiency, the intelligent features for open and closed-loop control are among the chief advantages of ebm-papst EC technology. From simply reading out the current speed to configuring a sensor control, the integrated electronics of all EC fans offer numerous options for optimally tuned and efficient operation of your system.

Depending on the planned use, application, work environment and existing equipment, various solutions provide assured communication with your ebm-papst EC fans. But which software is compatible with which bus system? Which interface converter connects which computer to which system?

On the following pages, we provide an overview of the combination options of our visualisation software with the MODBUS RTU and ebmBUS bus systems as well as the various communication standards, including *Bluetooth*[®] wireless technology.



GreenTech – economy and ecology going hand in hand

GreenTech follows a firmly held conviction: each newly developed product must exceed the economic and ecological performance of its predecessor. To this end, we are constantly improving materials and processes, flow behaviour and power – and reducing energy consumption. State-of-the-art energy, air-conditioning and ventilation technology provides maximum energy efficiency in our plant. Numerous environmental prizes, distinctions and the groundbreaking energy levels, which fall below even the most stringent limits, are the reward for our efforts.

GreenTech pays off for our customers, particularly due to the ebm-papst EC (electronically commutated) technology. It is not only the heart and soul of our philosophy, but also the core of our most efficient products. It attains efficiency up to 90 %, provides maximum energy savings and makes the products maintenance-free. With integrated open or closed-loop control and bus compatibility, it is an environmentally sound and, in the long run, more cost-effective alternative to AC technology.

The right protocol for every occasion

Regardless of whether a large number of nodes or broad scope of configuration options and mixed environments are in the focus of EC communication: software, hardware and interface converters from ebm-papst provide smooth data transfer based on ebmBus V3 and MODBUS RTU, two bus protocols that are particularly well suited for EC technology. For even more freedom of choice in implementation, control programs such as Fan Control for PDAs and EC Control for PCs even support both standards.

RS485 ebmBUS – the specialist for a high number of nodes

This bus protocol, developed by ebm-papst specifically for the requirements of EC technology, is perfectly designed for situations in which a large number of fans with little need for individual configuration are to be controlled. Up to 7,905 slaves can communicate with one master (PC/PDA). For this purpose, the Fan Control software program is available for mobile terminal units and LISA 5 as well as EC Control for PC-based platforms. RS485 ebmBUS, which has been continuously further developed and is now in its third generation, has proven to be a robust communication protocol that is equally easy to implement and use. Clean rooms are a typical application area.

RS485 MODBUS RTU – open standard with wide range of function

RS485 MODBUS RTU, which came into being back in 1979, has become established as a worldwide standard for controlling actuators and sensors, not least due to its open protocol. A great number of settings can be configured easily for up to 247 slaves. Each fan is assigned two parameter sets. They allow you to save different configurations, for example for summer and winter time, day and night or standard and high-performance mode. Three data sets per EC node also provide the ability to implement backup functions. In combination with read/write authorisations, an extensive fault memory and an emergency operation function, RS485 MODBUS RTU features outstanding characteristics in terms of both operating convenience and reliability. Typical application area in this case: refrigeration and air-conditioning technology.

Decide at a glance what is most important to you

	RS485 ebmBUS	RS485 MODBUS RTU
Baud rate	9,600	19,200
Parity	none	even
Number of nodes*	up to 7,905	up to 247
Profiles	–	•
Broadcast commands	•	–
Devices in the bus	only ebm-papst	ebm-papst and others
Configuration options	good	outstanding
Fault detection	XOR	CRC16
Fault memory	last 3	last 13
Software support	EC Control LISA 5 Fan Control Fan Clone	EC Control Fan Control Fan Clone

*On installations with more than 31 fans, RS485 repeaters have to be used, depending on the type of fan.

At a glance. The right software for the compatible interface.

Using the matrix on this page, we show you which control software communicates with which of the two bus systems, and from which input device. This allows you to understand the relationships at a glance. For direct comparison of the various strengths and features, to the right is an overview of the most important functions of the control software programs. This allows you to quickly and easily find out which combinations are best for your systems.

The perfect match: supported interfaces and protocols

Software	EC Control (page 6)	LISA 5 (page 7)	Fan Control (page 8)	Fan Clone (page 9)	EC controller (page 18)
Hardware	PC/laptop	PC/laptop	PDA/smartphone	PDA/smartphone	
Bluetooth adapter (page 10)			●	●	
RS232–RS485 interface converter with electrical isolation (page 12)	●	●	●	●	
RS232–RS485 interface converter without electrical isolation (page 14)	●	●	●	●	
Ethernet–RS485 interface converter (page 16)	●				
RS485 ebmBUS	●	●	●	●	
RS485 MODBUS RTU	●		●	●	●



Performance features of the control software programs for PCs and PDAs

	EC Control	LISA 5	Fan Control
Query and modify parameters of one fan	•	•	
Modify parameters for group/entire system	–	(•)	–
Group view/floors	•	•	(•)
Detailed error history when software runs for long periods	•	•	–
Mapping a system layout/floor plan	•	•	–
Search for a fan with an unknown address	–	•	•
Setting parameters graphically	–	–	•
E-mail on error	•	•	–
Manageability	(•)	(•)	•
Support for multiple languages	•	•	•
Support for RS485 ebmBUS	•	•	•
Support for RS485 MODBUS RTU	•	–	•
Support of Ethernet and multiple subnets	•	–	–
Duty cycle display on fan symbol	•	–	–
Display of information below fan symbol	•	–	–
Display of the system in a tree structure	•	–	–
Support of multiple configurations in one installation	•	–	–
German and English user manual (PDF)	•	–	•
Timer	–	•	–
Integrated help system (English)	•	–	–

Key:

- = Performance feature present
- (•) = Possible in part/to a limited extent
- = Not present

Special or universal?

Our high-performance control programs.



The ebm-papst EC Control and LISA 5 control programs enable detailed control and monitoring of fan groups in ebmBUS or ebmBUS and MODBUS RTU networks. The multilingual and intuitively operated interfaces in the familiar Windows® system environment provides you with easy and logical control. For example, you can position fans on the floor plan of your storey in a simple and clearly arranged manner. This lets you always keep tabs on your networks, even if they have many thousands of fans.

EC Control software for EC systems

EC Control enables visualisation and programming of ebmBUS and MODBUS RTU fan networks and can be configured for both serial and Ethernet interface converters. The software supports the maximum number of devices allowed by the respective bus system (up to 7,905 fans for ebmBUS and 247 for MODBUS RTU). For shorter latencies, multiple interface converters can be connected.

Where necessary, the variable user interface of EC Control makes it easy to distinguish between the various interface converters. It shows only the entries that are relevant to the specific system. Additional features include support of a second monitor, a tree-shaped management structure for finding individual fans in large systems efficiently and an online help.

Functions

- Configuring over 40 fan parameters such as operation mode, set values and control parameters
- Changing fan addresses
- Reading out fan parameters such as actual speed, serial number and production date
- Reading out fault status and fault memory
- Saving various configurations as an exportable and editable profile
- Monitoring installations, including the possibility of reporting failures by e-mail
- Administration of multiple systems within one program installation
- Support for RS232/RS485 and Ethernet/RS485 interface converters
- Simultaneous monitoring of ebmBUS and MODBUS RTU-based system components (requires several interface converters)



System version: EC-Control 1.01

Item number: 25714-2-0199

Delivery scope:

- CD-ROM with
- Software
 - German and English manuals in PDF format
 - Quick video guide

Languages: German, English

System requirements:

- Windows 2000 SP4 or higher, XP SP3 or higher, Vista SP1 or higher
 - 30 MB of free hard drive space
 - 512 MB RAM; for Vista, at least 1 GB RAM recommended
 - CPU Pentium III or higher, 800 MHz or comparable; for simultaneously operation with multiple interface converters, a faster CPU is recommended
 - Monitor with at least 1024 x 768 pixel resolution and 16-bit colour depth
 - CD-ROM drive (for installation only)
- At least one interface converter of the following types:
- RS232 (article No. 21487-1-0174) with electrical isolation
 - RS232 (article No. 21495-2-0174)
 - Ethernet (article No. 21488-1-0174)
 - Ethernet (UL certified) (article No. 21489-1-0174)

LISA 5 control software for EC systems

LISA 5 is the control software specially developed for ebmBUS. It is compatible with all EC motors and electronics that are networked via ebmBUS. The group-oriented arrangement of the fans enables individual control and monitoring of a maximum of 7,905 fans in up to 255 groups on 10 floors. Using broadcast commands, individual groups or all fans can be triggered simultaneously.

Functions

- Individual control and monitoring of max. 7,905 fans, including the ability to report failures by e-mail
- Group-oriented arrangement of the fans
- Level 1: Overview display for up to 10 floors
- Level 2: Overview display for up to 255 groups within a floor
- Level 3: Overview display for 31 fans within a group
- Broadcast command for one group or all fans
- Speed, temperature or pressure control
- Error message

- Fan status display
- Programming individual fans, e. g. changing the fan's address
- Changing the control mode of the fan (speed control/PWM control/sensor control)
- Changing set values (speed, direction of rotation etc.)
- Configuring control parameters
- Changing minimum/maximum values

- Read-out of fault status
- Identification of a fan with unknown fan address
- Configuring the sensor characteristics for sensor control
- Configuring the start-up and run-down ramp ("soft start")



System version: LISA 5.1

Item number: 25711-2-0199

Delivery scope:

CD-ROM with software

Languages: German, English, Spanish, French, Italian, Dutch, Finnish, Japanese, Chinese (simplified), Chinese (traditional), Russian

System requirements:

- Windows 2000, XP
- 21 MB of free hard drive space
- 128 MB RAM
- CPU Pentium 200 MHz or higher (or comparable)
- Monitor with at least 800 x 600 pixel resolution and 8-bit colour depth
- CD-ROM drive (for installation only)

- RS232 interface (for laptops, a PC card can also be used, but not a USB-RS232 adapter)
- At least one interface converter of the following types:
 - RS232 (article No. 21487-1-0174) with electrical isolation
 - RS232 (article No. 21495-2-0174)

Communication without cable clutter. The control software programs for Pocket PCs.



The Fan Control mobile software and its sister product, Fan Clone, are intuitive tools for wireless communication with ebmBUS and MODBUS RTU-compatible fan networks. Fan Control serves as a diagnostics and configuration tool for visualisation, monitoring and programming of fans. For this purpose, Fan Clone enables simplified commissioning of systems that consist of multiple identically configured fans. All configuration tasks and reading out and cloning fan configurations take place easily and conveniently via Bluetooth wireless technology.

Fan Control software for Pocket PC/PDA

Fan Control is compatible with both ebmBUS and MODBUS RTU devices. The software has graphical and numerical configuration options, allows you to save data records and two parameter sets, e. g. for daytime and nighttime operation. Using an emergency operation function, you can define a set value that the fan defaults to automatically if no bus communication takes place for a configurable time period.

Functions

- Monitoring of fan groups
- Fan status display
- Programming individual fans, e. g. changing the fan's address
- Changing the control mode of the fan (speed control/PWM control/sensor control)
- Changing set values (speed, direction of rotation etc.)
- Setting closed-loop control parameters (graphically, too)
- Changing minimum/maximum values
- Graphical configuration of minimum and maximum PWM as well as set value, for sensor control (pure P-controller), also the control range

- Read-out of fault status
- Search for unknown device addresses
- Configuring the sensor characteristics for sensor control
- Configuring the start-up and run-down ramp ("soft start")
- MODBUS RTU: graphical configuration of the curve of the 0–10 V analogue input, 10 V = off and 1 V = maximum duty cycle are thus no longer a problem!
- MODBUS RTU: reset the fan to the factory settings
- Read out a wide variety of fan parameters



System version: Fan Control 3.1

Item number: 25713-2-0199

Delivery scope:

CD-ROM with

- German and English manuals in PDF format
- Installation program (for every language)
- Video setup guide for the *Bluetooth* connection

Languages: German, English, Spanish, French, Italian, Dutch, Finnish, Japanese, Chinese (simplified), Chinese (traditional), Russian

System requirements:

- ebm-papst *Bluetooth* Adapter (article No. 21501-1-0174), alternative: RS232 interface converter with cable (article No. 21500-1-0174)
- Pocket PC/PDA or smartphone with resolution of at least 240 x 320 pixels
- Windows Mobile 5 for Pocket PC or
- Windows Mobile 5 Phone Edition or
- Windows Mobile 6 Classic or
- Windows Mobile 6/6.1 Premium

An always up-to-date list of compatible devices is available at www.ebmpapst.com/downloads



Fan Clone commissioning software for Pocket PC/PDA

Fan Clone allows you to efficiently program configuration variants produced in small lots. After the configuration of one fan is read out and stored, the read-out or stored configuration is transferred to other fans, with or without changing the device address of the target fan. Fan Clone also identifies fans with an unknown fan address.

Functions

The following parameters can be copied onto other fans using this software:

- Operating mode (closed-loop speed control/sensor control/PWM control)
- Save set value to EEPROM
- Source of set values (BUS vs. analogue input)
- Control function (heating/cooling)
- Default set value
- P-, I-, D**-factor
- Maximal speed
- Min./max. PWM
- Start PWM
- Set value 0 and 1 (active with digital interpretation of analogue input)**
- Reduction factor**
- Sensor minimum/maximum value
- Sensor unit
- Run-up and run-down time
- Sampling interval of current regulator
- Source for control function, bus vs. external terminal (switch)*
- Output function of analogue output*
- Output curve of analogue output*
- Emergency operation function*

* MODBUS RTU

** ebmBUS



System version: Fan Clone 2.0

Item number: 25715-2-0199

Delivery scope:

CD-ROM with

- English manual in PDF format
- Installation program
- Video setup guide for the *Bluetooth* connection

Language: English

System requirements:

- ebm-papst *Bluetooth* Adapter (article No. 21501-1-0174), alternative: RS232 interface converter with cable (article No. 21500-1-0174)
- Pocket PC/PDA or smartphone with minimum resolution of 240 x 230 pixels and *Bluetooth* interface
- Windows Mobile 5 for Pocket PC or
- Windows Mobile 5 Phone Edition or
- Windows Mobile 6 Classic or
- Windows Mobile 6/6.1 Premium

An always up-to-date list of compatible devices is available at www.ebmpapst.com/downloads

Bluetooth interface adapter

RS485



For wireless programming and monitoring, ebm-papst fans equipped with an RS485 interface can communicate with Pocket PCs/PDAs or smartphones via the ebm-papst Bluetooth Adapter. Diagnostics in the event of fault are likewise possible. To do so, the Bluetooth Adapter creates a bi-directional connection from RS485 units to Bluetooth-compatible PDAs or smartphones.

Nominal data

Type	21501-1-0174	
Power supply	VDC reversible	15–24
Current draw	mA	30
Transmitting power	mW	1
Range (depending on ambient conditions)	m	10–20
Dimensions	mm	100 x 50 x 25

Operating mode	RS485, two-wire mode without echo, automatic switchover between send and receive
RS485 connection	Molex Minifit socket (compatible plug: Molex, article No. 43025-0400 and 43030-0001)
Frequency band	ISM band (2402–2480 MHz)
Status display	Via LED – Green: power supply OK – Yellow (flashing): <i>Bluetooth</i> connection active – Red (top, left of green LED): data transmission from PDA/smartphone to fan – Red (bottom, left of yellow LED): data transmission from fan to PDA/smartphone
Housing	Plastic housing
Type of protection	IP 20
Delivery scope	– <i>Bluetooth</i> Adapter and 4-conductor connecting cable with corresponding Molex plug and core-end sleeves – German and English product description



Connecting the Bluetooth Adapter – example of a fan with MODBUS RTU compatibility

The Bluetooth Adapter is connected directly to the fan. The fan voltage of 15 or 20 V is used for the power supply of the adapter so that no external power supply is required.

Note: Reversing the voltage does not present any problems for the Bluetooth Adapter, even if the fan displays an error regarding this.

The Bluetooth Adapter works in the same licence-free 2.4 GHz frequency band in which Wireless LAN networks operate. The frequency hopping method used here provides immunity to interference.

Note: Only one Bluetooth Adapter is needed for communication with a system, no matter what its size.

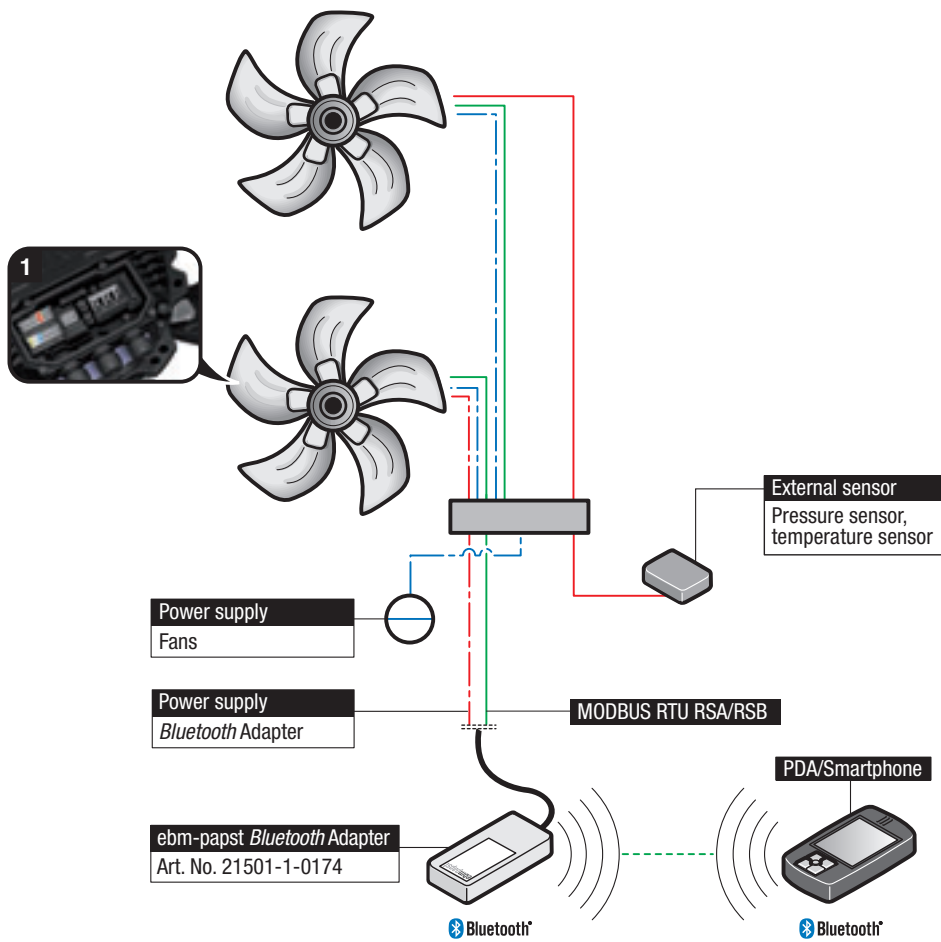

1 Example terminal assignment for fan

KL3				KL2		PE		KL1		
Din2	Din3	GND	Ain2 U	+20V	Ain2 I	Aout				
RSA	RSB	GND	Ain1 U	+10V	Ain1 I	Din1	NO	COM	NC	PE
										L1
										L2
										L3

Interface converter

RS232–RS485 with electrical isolation



This interface converter permits bi-directional connection of RS232 devices (laptop or PDA) with bus-compatible devices (electronic commutation units with RS485 interface). The interface features electrical isolation between the RS232 and RS485 sides.

Nominal data

Type	21487-1-0174	
Nominal voltage and plug-in supply unit	VAC	230
Power supply	VAC/VDC	12–14
Current draw at no-load operation	mA	150
Dimensions	mm	105 x 75 x 22

Operating mode	RS485, two-wire mode with echo and automatic control
Safety	Electrical isolation between RS232 and RS485
Electrical isolation	Min. 1kV isolation voltage between RS232 and RS485 interfaces and between power supply and interfaces
ESD immunity	Up to 15 kV (acc. to IEC 801-2, Stage 4)
RS232 connection	9-pole SUB-D plug with PC-COM assignment
RS485 connection	9-pole SUB-D plug
Terminating resistor	built-in, activated via switch
Status display	Via LEDs – Green: supply voltage OK – Red: data transfer
Housing	Plastic housing
Installation	Standard rail mounting in accordance with DIN EN 50022-35
Delivery scope	– Interface converter – Plug-in supply unit (230 VAC/12 VDC, 500 mA) – Adapter lead to the computer with 2 x 9-pole SUB-D sockets – Adapter lead to the fan with 9-pole SUB-D socket and RS485 screw terminal – Product description and manual (German and English)

Connecting the interface converter – example of a fan with MODBUS RTU compatibility

In conjunction with the EC Control or LISA 5 programs, connections for bus-compatible fans can be implemented easily using a computer or laptop. No special setup of the interface converter is required.

Note: Because of the electrical isolation, use in even large networks with potential differences is possible without any problems.

Note for large systems: After 31 fans, a repeater can be installed in order to connect another 31 fans.

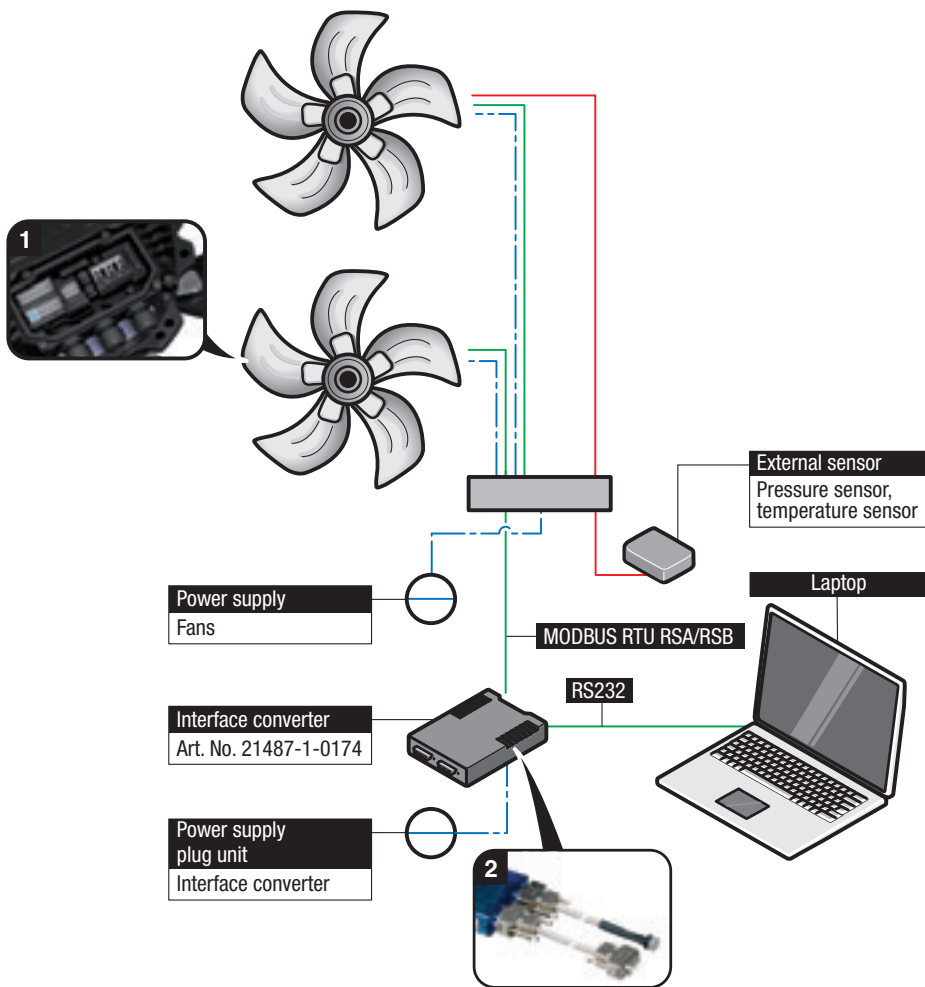

1 Example terminal assignment for fan

KL3							KL2			PE	KL1		
Din2	Din3	GND	Ain2 U	+20V	Ain2 I	Aout							
RSA	RSB	GND	Ain1 U	+10V	Ain1 I	Din1	NO	COM	NC	PE	L1	L2	L3

2 Interface converter connection

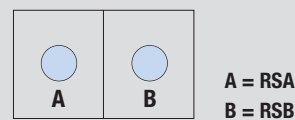

Interface converter

RS232 – RS485



This interface converter permits bi-directional connection of RS232 devices (laptop or PDA) with bus-compatible devices (electronic commutation units with RS485 interface). The power supply is from the RS232 output of the laptop or PDA.

Nominal data

Type	21495-2-0174	
Dimensions	mm	73 x 37 x 19
Power supply	VDC	7–12*

*Otherwise via RS232 DTR, TxD and RTS signal

Operating mode	RS485, 2-wire mode with echo and automatic control
Status display	Via LEDs – PWR: Power supply – TXD: Data transfer (send) – RXD: Data transfer (receive)
Housing	Plastic housing
Terminal	Screw terminal, TRX+ = RSA, TRX– = RSB
Terminating resistor	Built-in, activated via switch
Delivery scope	– Interface converter – English-language operating manual

Connecting the interface converter – example of a fan with MODBUS RTU compatibility

The combination with the EC Control and LISA 5 programs enables cost-effective programming and monitoring of bus-compatible EC fans. The interface converter can be connected directly and used without any special setup.

Note: The interface converter does not have any electrical isolation and thus is suitable for battery-operated devices only. The switch (on top of the interface converter) must be set to RS485.

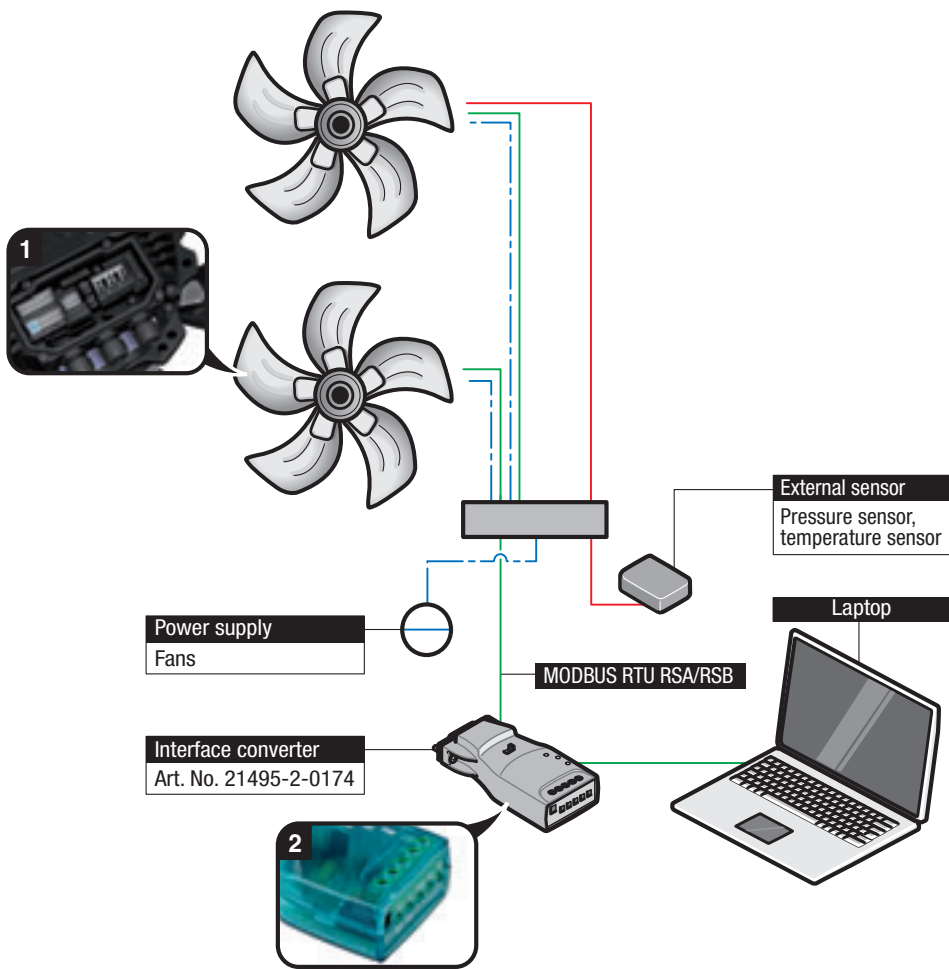

1 Example terminal assignment for fan

KL3				KL2		PE		KL1		
Din2	Din3	GND	Ain2 U	+20V	Ain2 I	Aout				
RSA	RSB	GND	Ain1 U	+10V	Ain1 I	Din1	NO	COM	NC	PE
										L1
										L2
										L3

2 Interface converter connection



Ethernet interface converter

RS485



This interface converter permits bi-directional connection of RS485 units and Ethernet-compatible computers or laptops using the EC Control software (article No. 25714-2-0199)

Nominal data

Type		21488-1-0174	21489-1-0174 (UL version)
Nominal voltage and plug-in supply unit	VAC	100–240	100–240
Power supply	VDC	12–48	12–48
Current draw	mA	85	85
Frequency	Hz	50/60	50/60
Ambient temperature (arranged in series)	°C	0 to +50	0 to +50
Ambient temperature (not arranged in series)	°C	0 to +60	0 to +60
Dimensions	mm	105 x 75 x 22	105 x 75 x 22

Operating mode	RS485, two-wire mode without echo, automatic switchover between send and receive
Safety	Electrical isolation between Ethernet and RS485
Electrical isolation	min. 500 V
Ethernet connection	8-pole RJ45 socket 10/100 Mbps autosensing
RS485 connection	9-pole SUB-D plug
Protocols used	– TCP – Telnet
Status display	Via LEDs – Green (left): power supply – Green (right): data communication – Red: fault
Housing	Plastic housing
Type of protection	IP 10
Installation	Standard rail mounting in accordance with DIN EN 50022-35
Delivery scope	– Interface converter – Plug-in supply unit – RS485 cable, D-Sub to screw terminal – Network cable (crossover, Cat 5) – German and English product description

Connecting the interface converter (Ethernet) – example of a fan with MODBUS RTU compatibility

The Ethernet interface converter serves to integrate bus-compatible EC fans into existing computer networks. This increases the spatial independence of the control room and fans. Other than a power supply, all that is needed is a static IP address, which can be assigned easily using the EC Control software. Multiple Ethernet interface converters can be used without any problems. This allows, for example, larger systems to be divided up spatially to reduce latencies.

Note for large systems: After 31 fans, a repeater can be installed in order to connect another 31 fans.

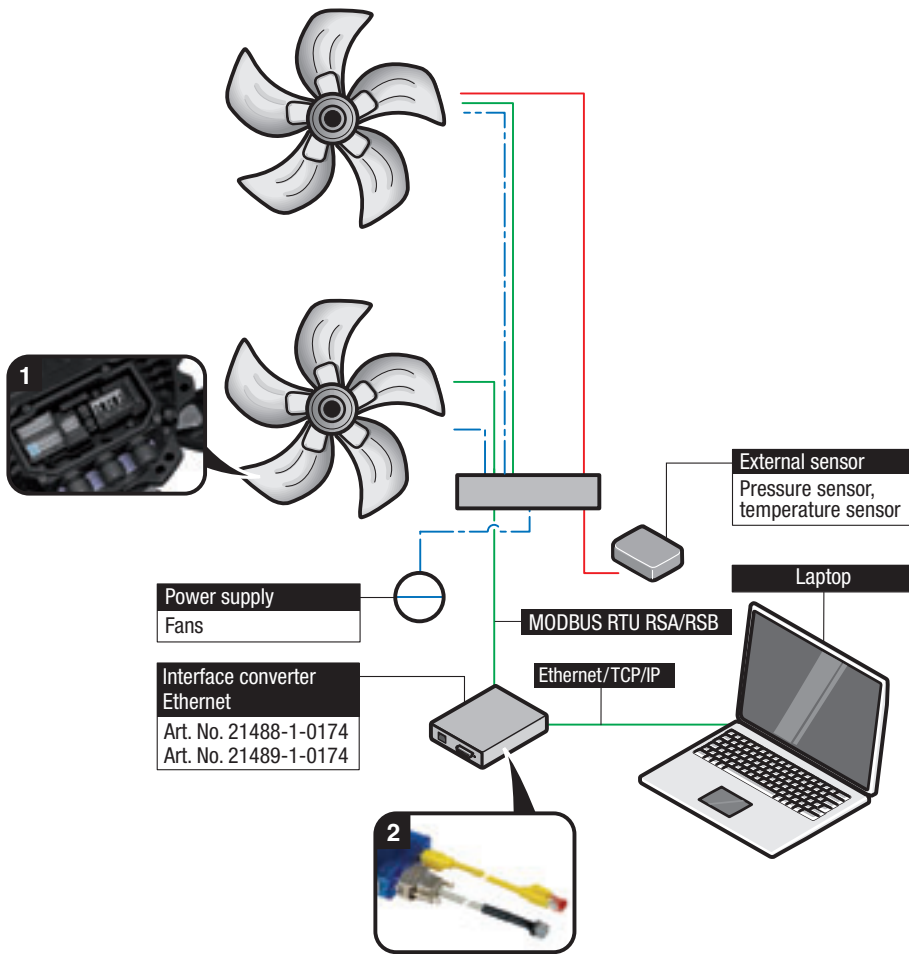

1 Example terminal assignment for fan

KL3							KL2			PE	KL1		
Din2	Din3	GND	Ain2 U	+20V	Ain2 I	Aout							
RSA	RSB	GND	Ain1 U	+10V	Ain1 I	Din1	NO	COM	NC	PE	L1	L2	L3

2 Interface converter connection

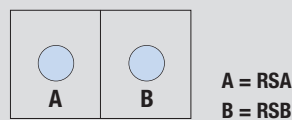

EC controller



Stand-alone control device for refrigeration and air-conditioning technology in conjunction with the corresponding sensors. Using the controlled 0–10 V output or RS485 MODBUS RTU connection, ebm-papst fans with a corresponding input can be triggered. The function includes multifunctional pressure and temperature control as well as display and entry of various parameters. The integrated LCD display provides easy operation across multiple levels.

Nominal data

Type	CCC000-AD06-02	
Nominal voltage	V	1~200–480
Frequency	Hz	50/60
Power consumption	W	15
Power supply for sensor	VDC	24
Output current	mA	120
Permitted ambient temperature	°C	0 to +60
Permitted storage temperature	°C	–20 to +60
Dimensions	mm	200 x 167 x 76

Specifications subject to change!

Inputs/outputs	<ul style="list-style-type: none"> – 24 V power supply for sensors – Analogue inputs for connecting up to 2 sensors per type – 4 digital inputs – 2 programmable relay outputs, 2 voltage outputs 0–10 V – RS485 MODBUS RTU
Applications	<ul style="list-style-type: none"> – Temperature control, standard – Pressure control of ventilation systems, condensers, 2-circuit condensers – Pressure control, ambient temperature-compensated <p>These applications are the factory defaults. Other applications can be programmed individually.</p>
Sensors	<ul style="list-style-type: none"> – Temperature sensor KTY 10-6 (R25 = 2 kΩ), NTC 103AT (R25 = 10 kΩ) – Pressure sensor 0 to 100/200/500/1000 Pa (0–10 V output), 0 to 30 bar (4–20 mA output) – ebm-papst temperature sensors, Art. No. 50003-1-0174 and 50005-1-0174 – Other sensors can be programmed individually
Menu languages	German/Swedish/Danish/English (factory setting)
Housing	Plastic housing
Product conforming to standard	CE
Type of protection	IP 54 (acc. to DIN EN 60529)
EMC	Acc. to EN 61000-6-3 and EN 61000-6-2
Installation	Vertical wall mounting, direct solar radiation and installation on vibrating substrate is not permitted. Electrical leads via terminal strips

Connecting the EC controller – example of a fan with MODBUS RTU compatibility

The EC controller functions as a stand-alone control device for fan networks in combination with external sensors. Factory default applications ensure easy commissioning – connecting a computer or other software-supported devices is not necessary. For programming new applications and for monitoring, an integrated keypad control with LCD display replaces the external input devices.

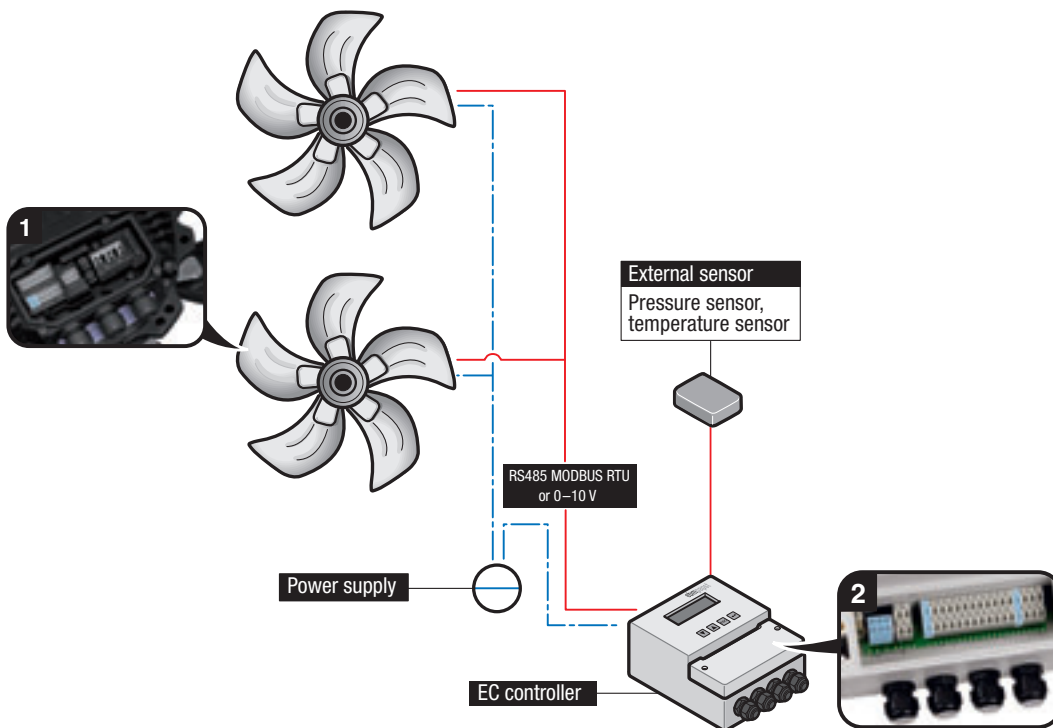

1 Example terminal assignment for fan

KL3						KL2			PE	KL1		
Din2	Din3	GND	Ain2 U	+20V	Ain2 I	Aout1				L1	L2	L3
RSA	RSB	GND	Ain1 U	+10V	Ain1 I	Din1	NO	COM	NC	PE		

2 Example terminal assignment – EC controller

KL1			KL2						KL3											
1	2	3	Relais 1		Relais 2		GND	GND	0-20 mA	0-20 mA	GND	GND	GND	GND	D1	D2	D3	D4		
L1	N/L2	PE	Relais 1	Relais 2	Temp	Temp	+24 V	+24 V	0-10 V I	0-10 V I	0-10 V 0	0-10 V 0	GND	GND	GND	GND	RSB	RSB	Temp	Temp

In this brochure, we hope to give you a comprehensive overview of how the hardware and software of our EC communication products interact. If you have any other questions about a specific application, please do not hesitate to contact us. Our specialists will be happy to help.

ebm-papst
Mulfingen GmbH & Co. KG

Bachmühle 2
D-74673 Mulfingen
Phone +49 7938 81-0
Fax +49 7938 81-110
info1@de.ebmpapst.com

www.ebmpapst.com